

# Catalyst Module

Based on the Intel® Atom™ Processor, the Catalyst Module Beefs Up Performance while Maintaining Low Power

## HIGHLIGHTS

- Intel® Architecture in small form factor
- Increased performance and efficiency
- Microsoft XP, XPe, CE, Vista and Linux support
- Low heat generation for fanless applications
- Flexible modular design for easy customization and quick time to market

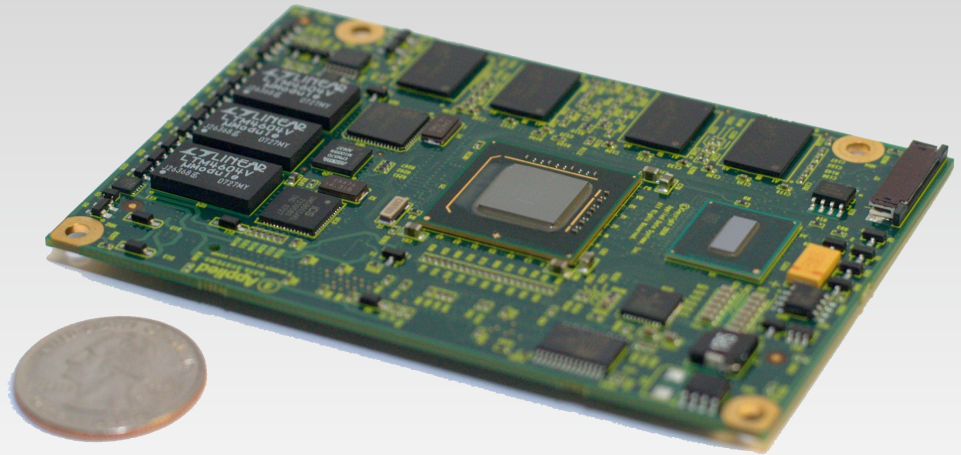

## DESCRIPTION

**Build low power, fanless embedded solutions based on the latest Intel technology using the Catalyst module.** Develop advanced embedded solutions without making trade-offs between performance and power consumption with the Catalyst Module. The Catalyst Module from Applied Data Systems is based on the Intel® Atom™ Processor and the Intel System Controller Hub (SCH) US15W. The Intel Atom processor is implemented using Intel's industry first 45nm, High-K technology to offer high-end performance while reducing thermal constraints and power consumption. The Intel Atom processor is validated with the SCH US15W chipset which integrates graphics, memory, and I/O into a small package.

Applied Data's Catalyst Module leverages the advantages of this Intel technology to provide an ideal embedded solution for high performance, low power applications such as ruggedized handheld, multimedia, medical, point of service, and industrial designs. The Catalyst Module maintains a small form factor and offers comprehensive I/O and multimedia capabilities including high definition graphics while maximizing the MIPS to mW ratio and consuming less than 5W of power per system. The two-card design gives customers flexibility with the adapter board, starting either with a standard version or custom design (by Applied Data or a third party) to meet unique application requirements while reducing time to market. Furthermore, the Catalyst Module offers further flexibility by supporting several operating system options including Windows CE, XP, XPe, Vista, Linux, and targeted real time operating systems (RTOS).

## SPECIFICATIONS\*

## CATALYST MODULE BLOCK DIAGRAM

### PROCESSOR

- Intel Atom Processor up to 1.6 GHz
- 533 MHz front side bus
- Intel SCH US 15W

### GRAPHICS/VIDEO/TOUCHSCREEN

- Video Interfaces: UXGA, XGA, SXGA, HD
- Codecs: H.264, MPEG-4/2/1, Windows Media-9, DivX
- Dual independent display output capability

### AUDIO

- Intel HD Audio

### MEMORY

- 533Mhz DDR-2 up to 1GB
- Up to Three SD/MMC Cards
- Up to Two PATA Disk Drives

### OPERATING ENVIRONMENTS

- Windows® XP, XPe, CE, Vista
- Linux
- Specific RTOS support (call for details)

### MANAGEMENT

- Advanced Power Control
- System Health/Environmental Monitor
- ACPI Power Management

### PHYSICAL/OTHER

- Module dimensions 2.8 x 3.9 inches (67 x 100 mm)
- Temp. range up to -40°C to 85°C
- Power consumption 2W – 3W average per typical application
- Maximum sustained power consumption < 5W

### PERIPHERALS

- Onboard Real Time Clock
- Up to Eight Universal Serial Ports (USB 2.0)

### ADAPTER BOARD EXPANDABILITY

- Serial Ports (RS-232, RS-485, Optically Isolated)
- 4 or 5 wire Touch Screen Interface
- Parallel Port
- IrDA Interface
- Digital I/Os
- Analog I/Os
- CanBUS
- 10/100/1000 LAN
- PCI-Express for High Speed I/O
- Mini-PCIe for Wireless Applications
- Microphone and Speaker Audio

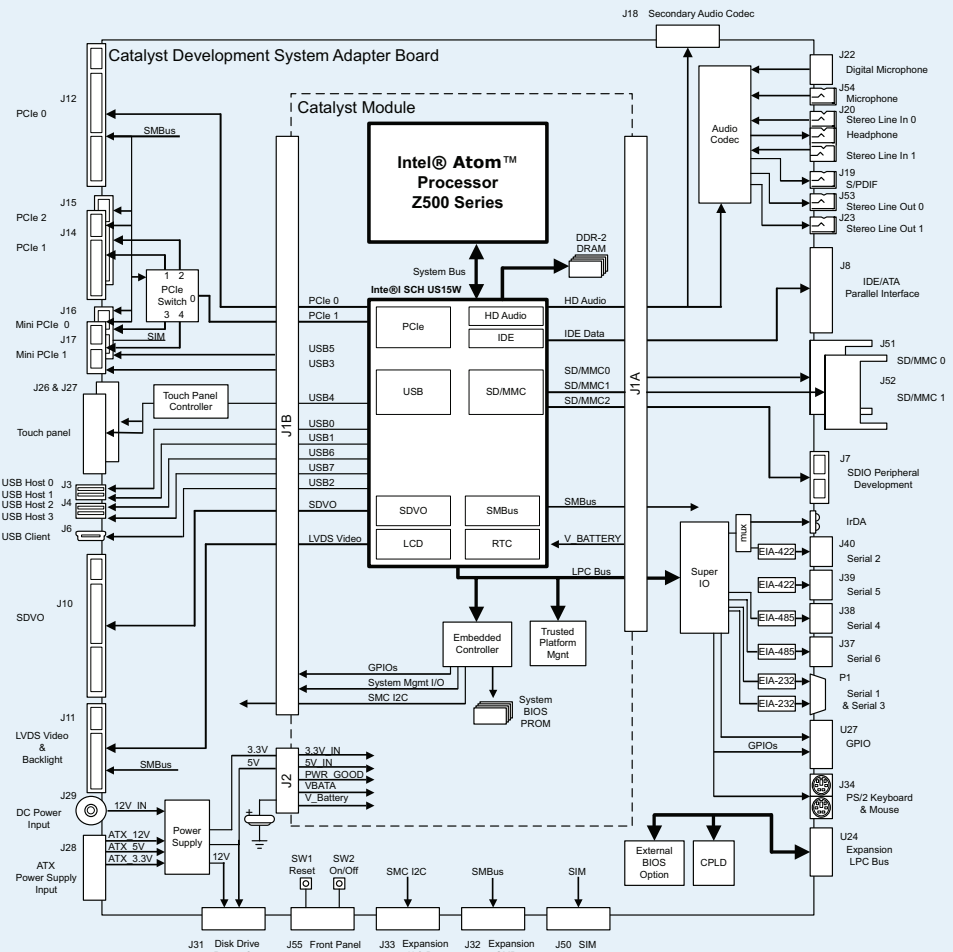

### The Embedded System Architects

Applied Data Systems is a leading manufacturer of single board computers used in process control, medical instrumentation, environmental monitoring, fleet management, kiosks, voting systems and industrial automation equipment.

With 20 years of graphics hardware and software development experience, Applied Data uniquely delivers customized display connectivity, device support, and network communications. Applied Data Systems, a Eurotech Group company, is ISO 9000 certified, with headquarters in Columbia, Maryland, USA.

Catalyst Module is a trademark of Applied Data Systems. Other trademarks are property of their respective holders.

\*Subject to change without notice.  
CMM4483C April2008v1.0